



# NuSTRAP trips in rare-earth land

Theo J. Mertzimekis  
for the NuSTRAP Group at  
National and Kapodistrian  
University of Athens



$A \approx 120-180$

- Focus is on the 50-82 shell:
  - huge space
  - fertile ground for nuclear structure studies
  - single-particle degrees of freedom compete with collective phenomena
  - p-n are in different shells
- Kind of surprising: experimental data in this mass region are rather scarce, esp. lifetimes of  $\beta$ ,  $\gamma$  bands and more

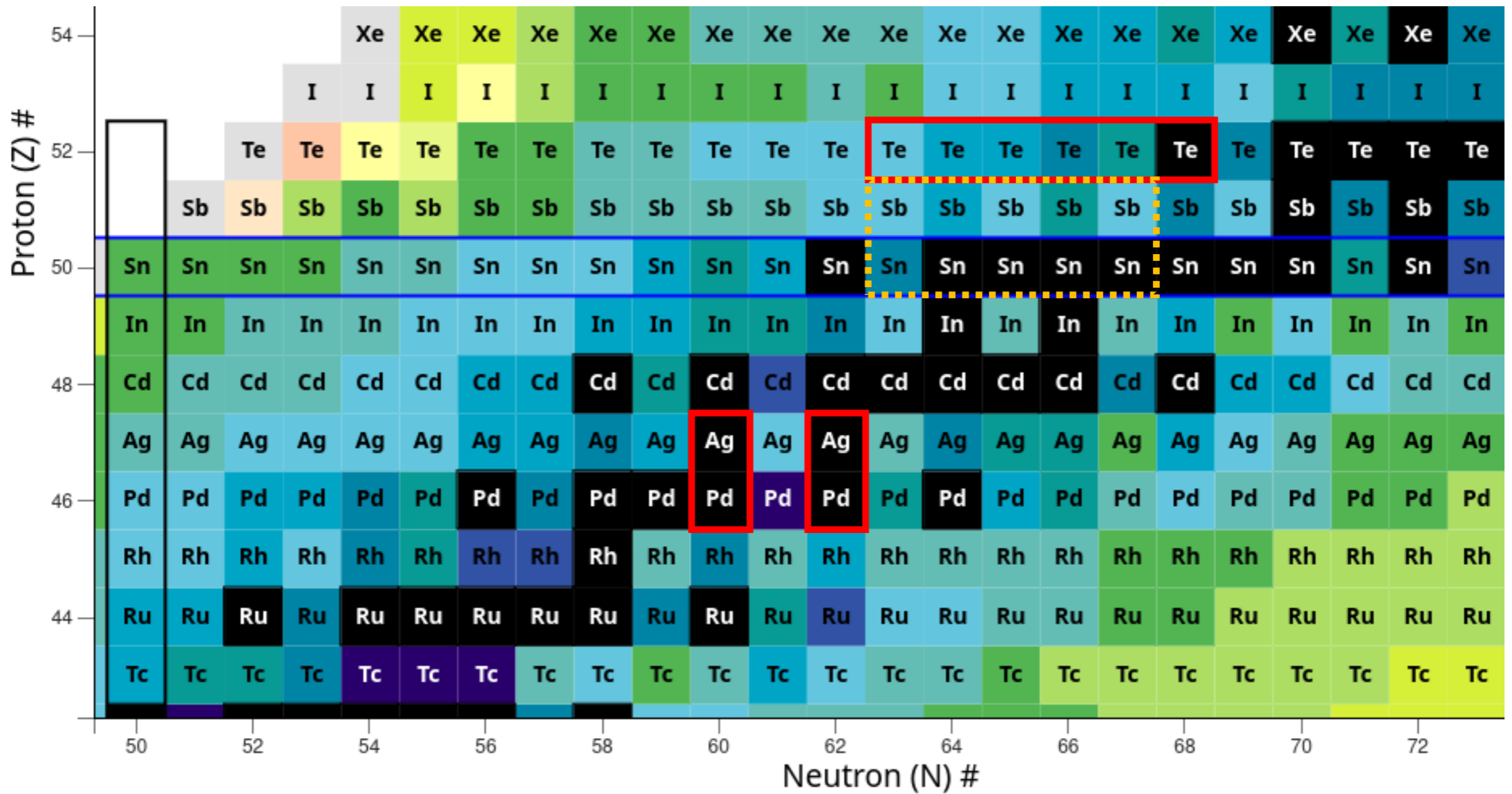

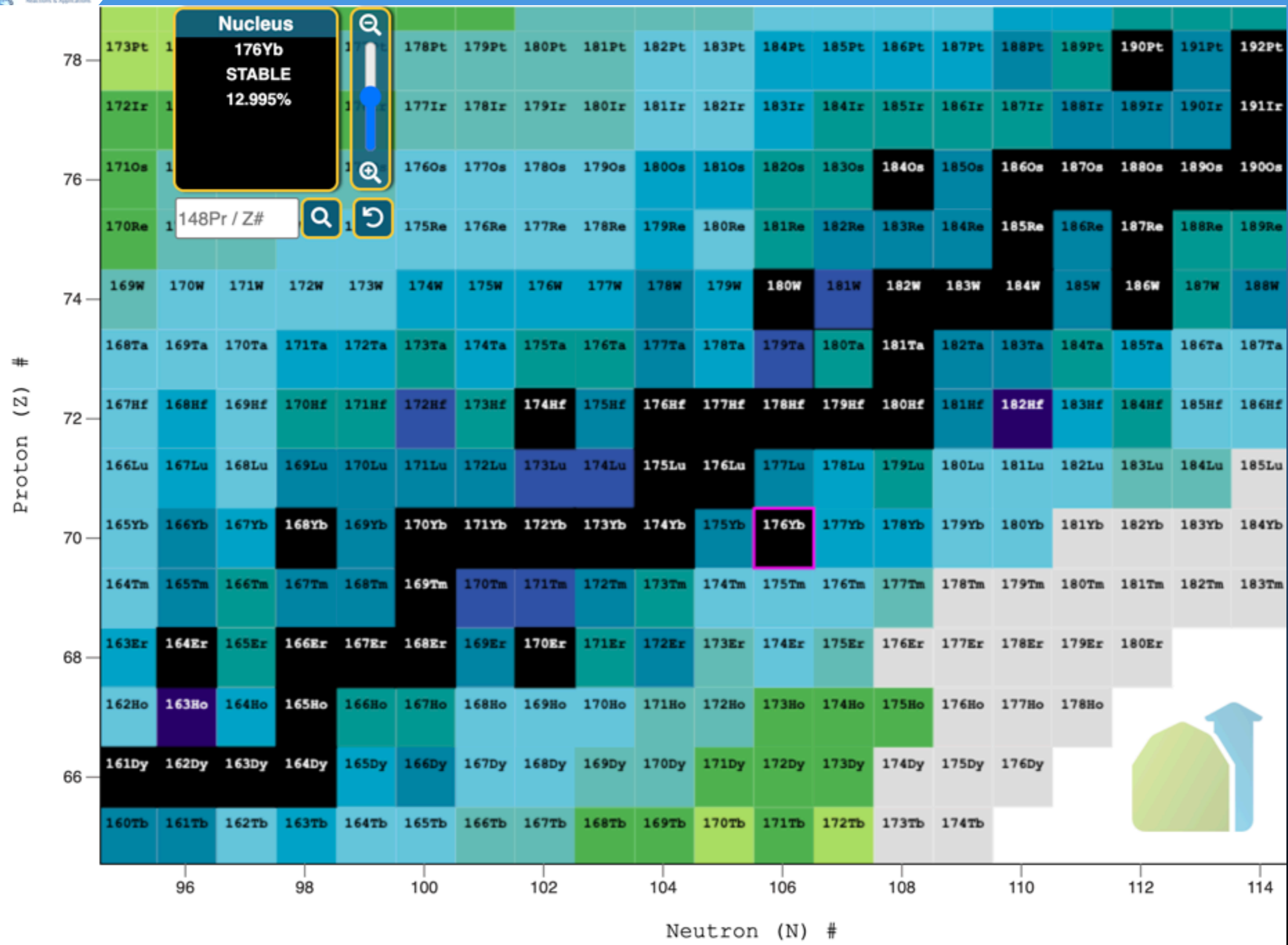

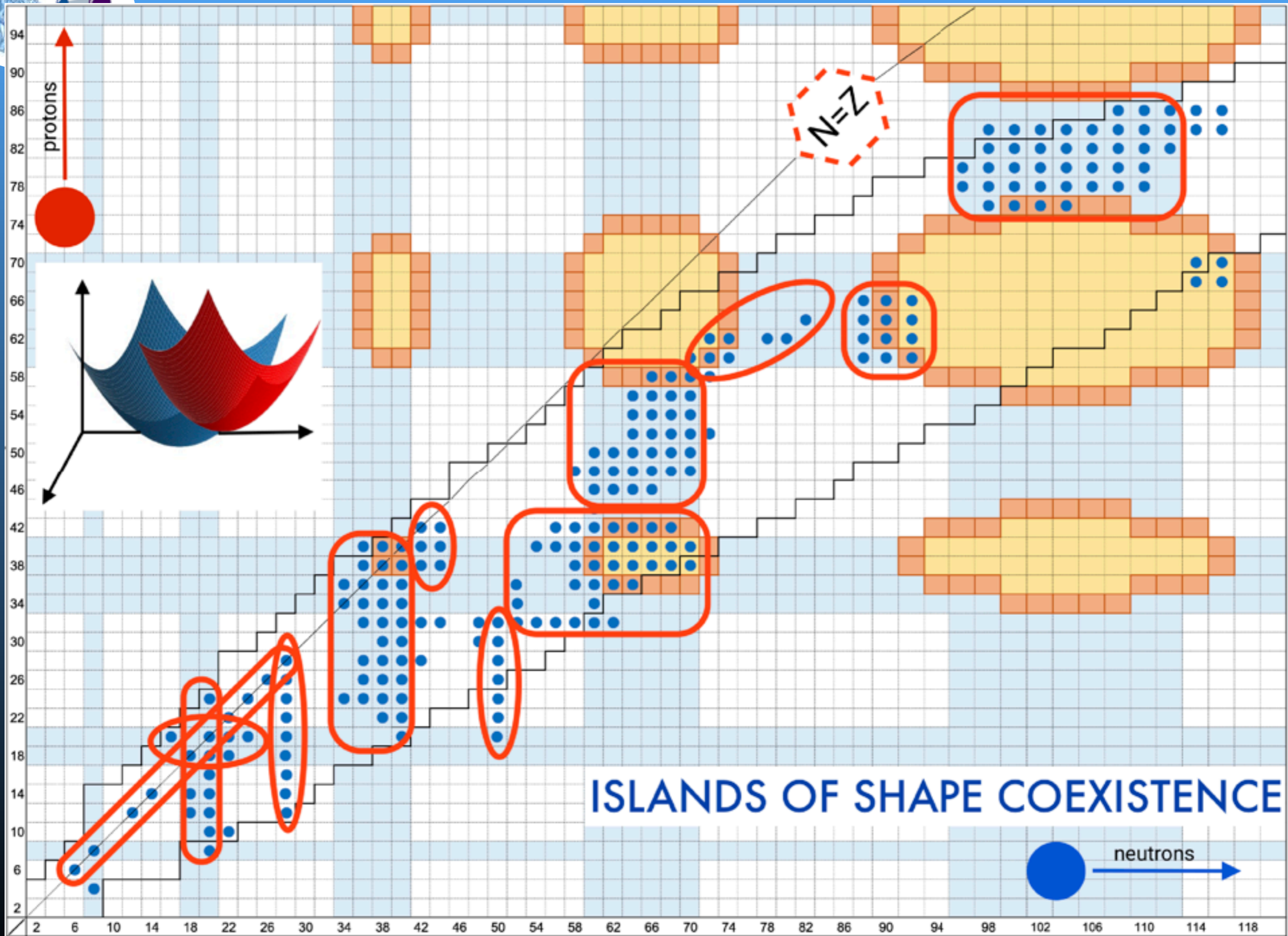

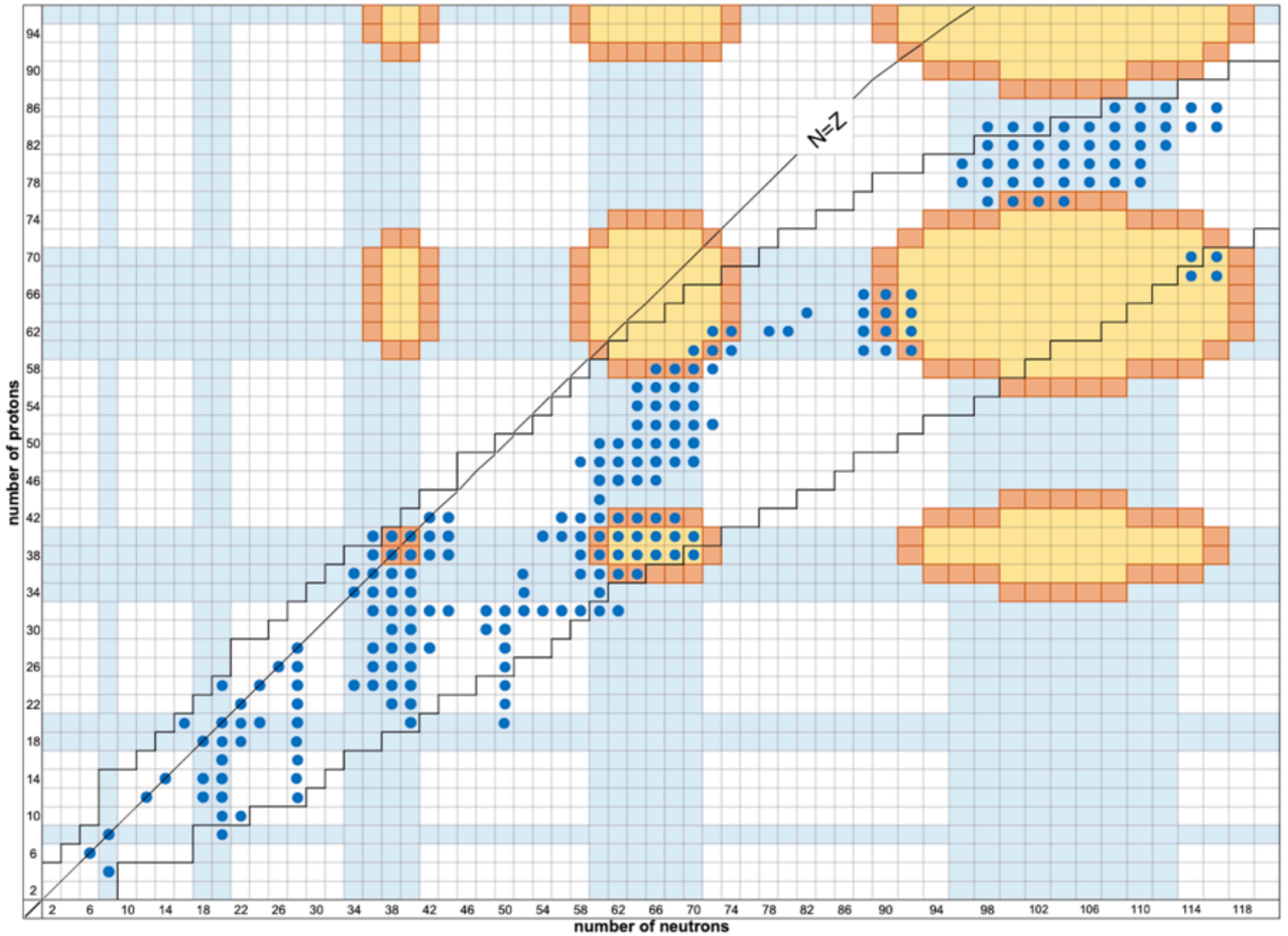

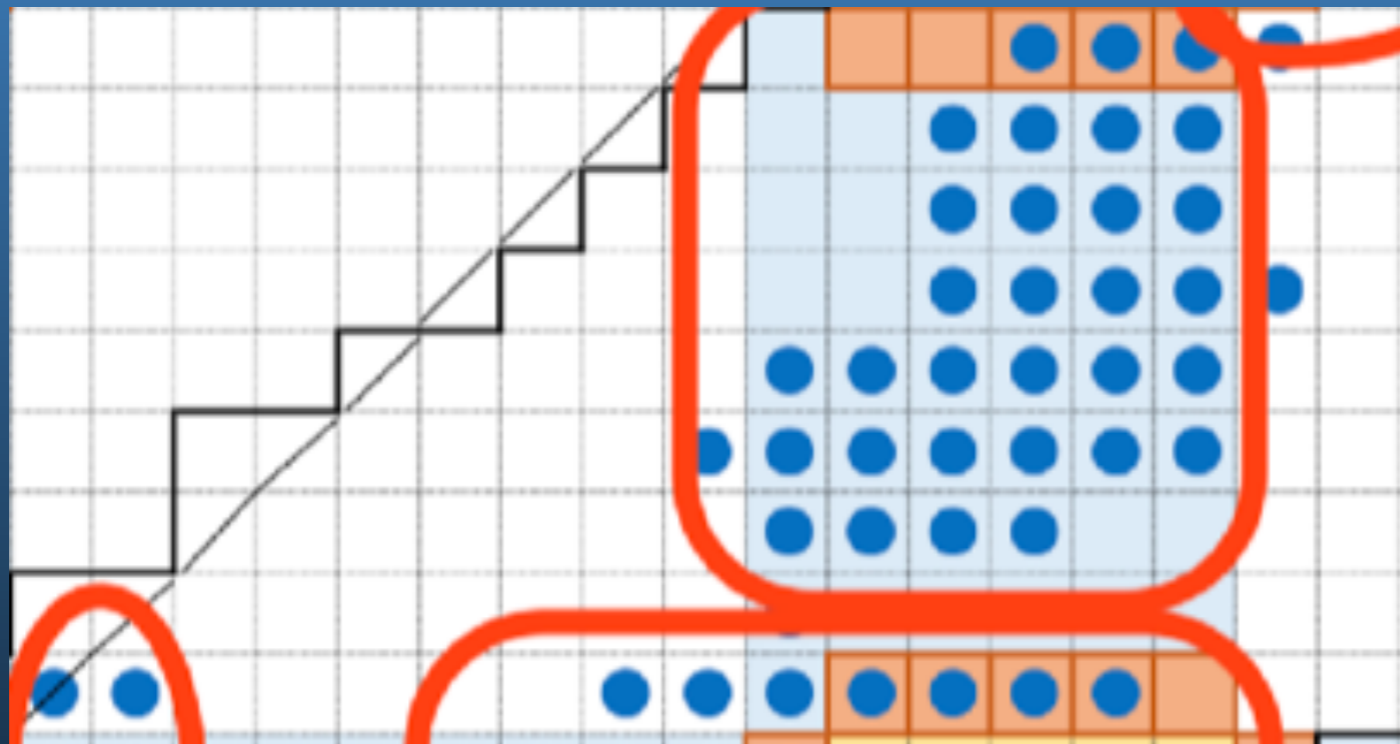

← Te  
← Sn  
← Cd  
← Pd



# Experimental details

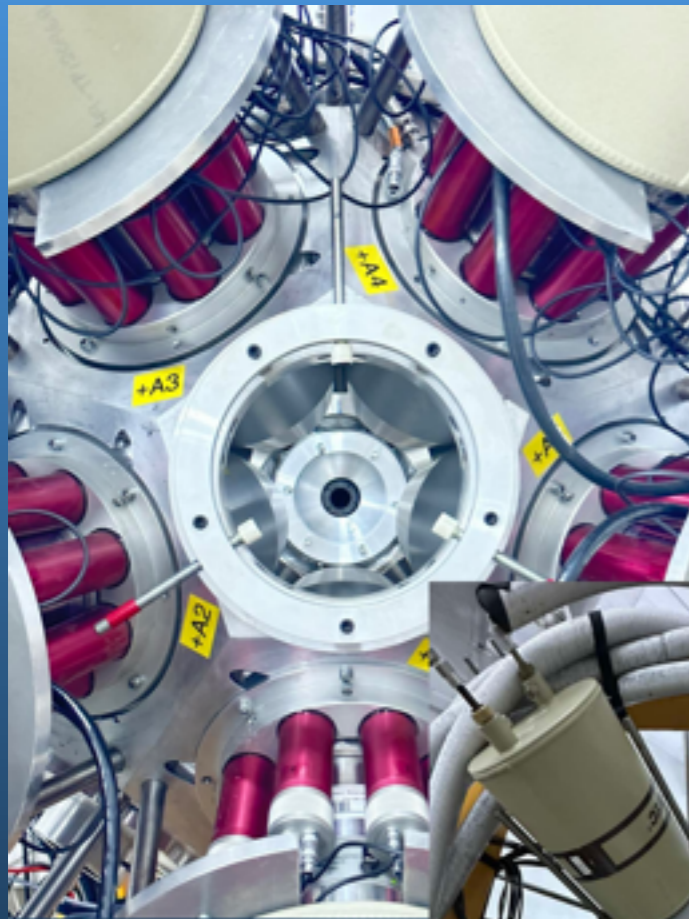

photos: A. Zyriliou



$^{11}\text{B} + \text{natAg}$  at a beam energy of 35 MeV



$^{107,109}\text{Ag}$  (elastic)

$^{115-120}\text{Te}$  (fusion evaporation)

$^{106,108}\text{Pd}$  (proton pickup)

RoSPHERE: 15 HPGe + 10 LaBr3

Lifetime measurements with the Fast Electronic Scintillation Timing (FEST, or fast-timing) technique



# Time-walk corrections

An important first step to apply the technique

Some technical jargon:

$^{152}\text{Eu}$  standard source  $\rightarrow$  Construct  $E_\gamma E_\gamma \Delta T$  matrices.  $\rightarrow$  Extract the **prompt time-centroids** for a subset of  $E_\gamma - E_\gamma$  full-peak coincidences.  $\rightarrow$  Perform **walk correction**, re-align the centroids, expand outward and repeat for the full set.

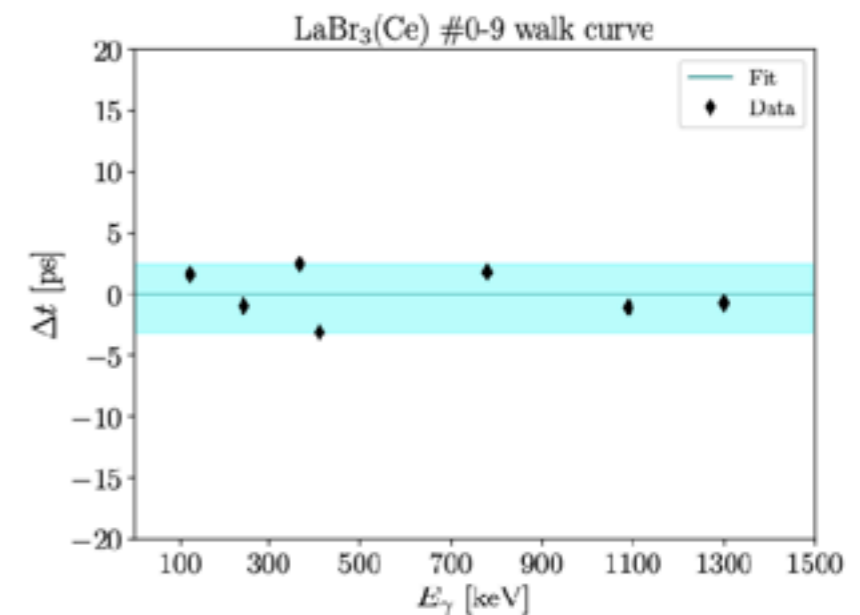
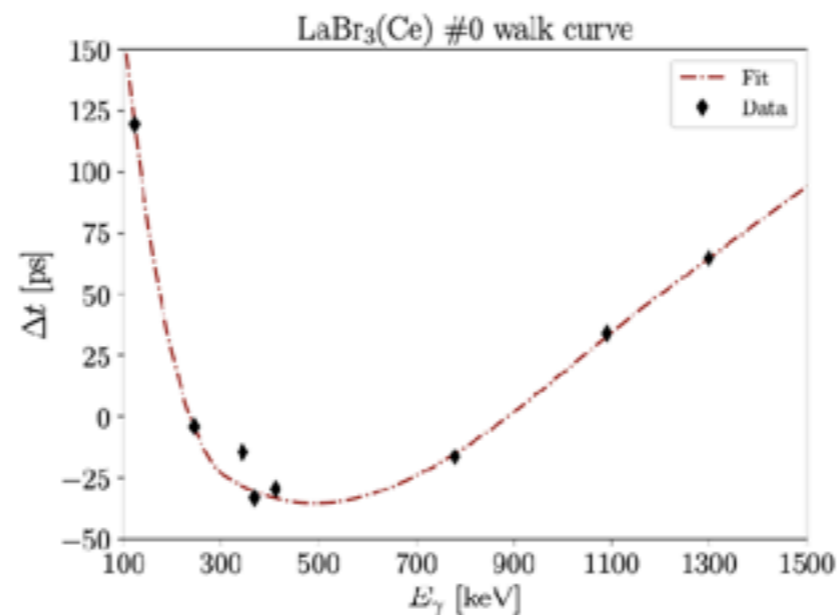
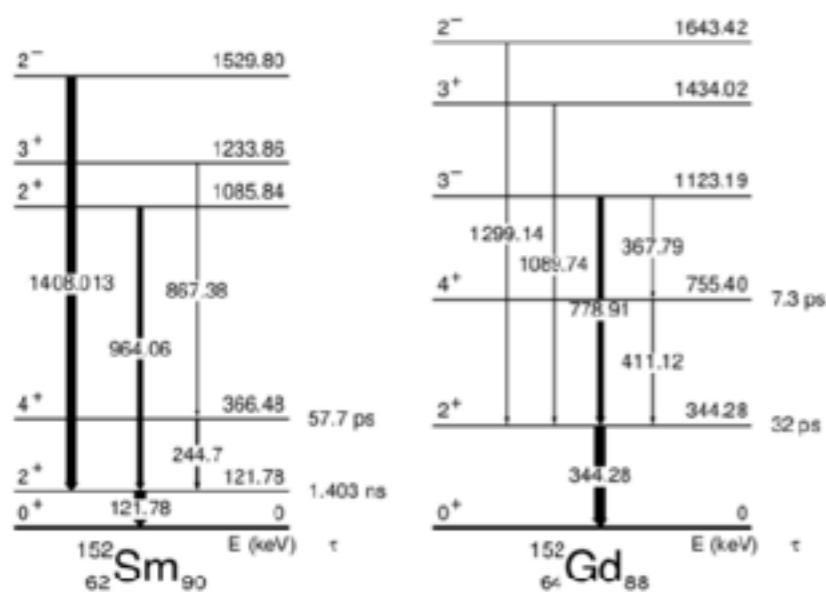

SORCERER particle energy spectrum

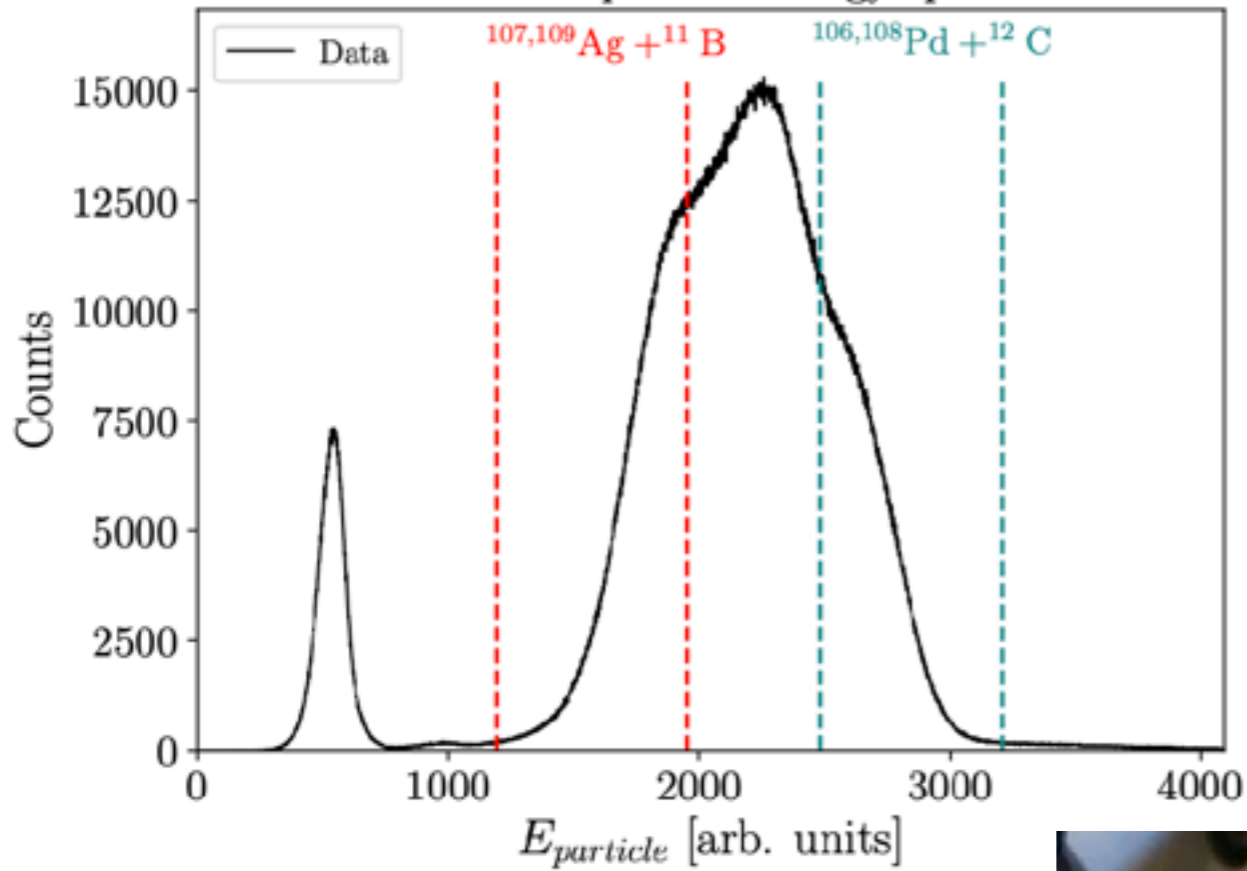

LaBr<sub>3</sub>(Ce) spectrum, gated on the <sup>12</sup>C particle peak

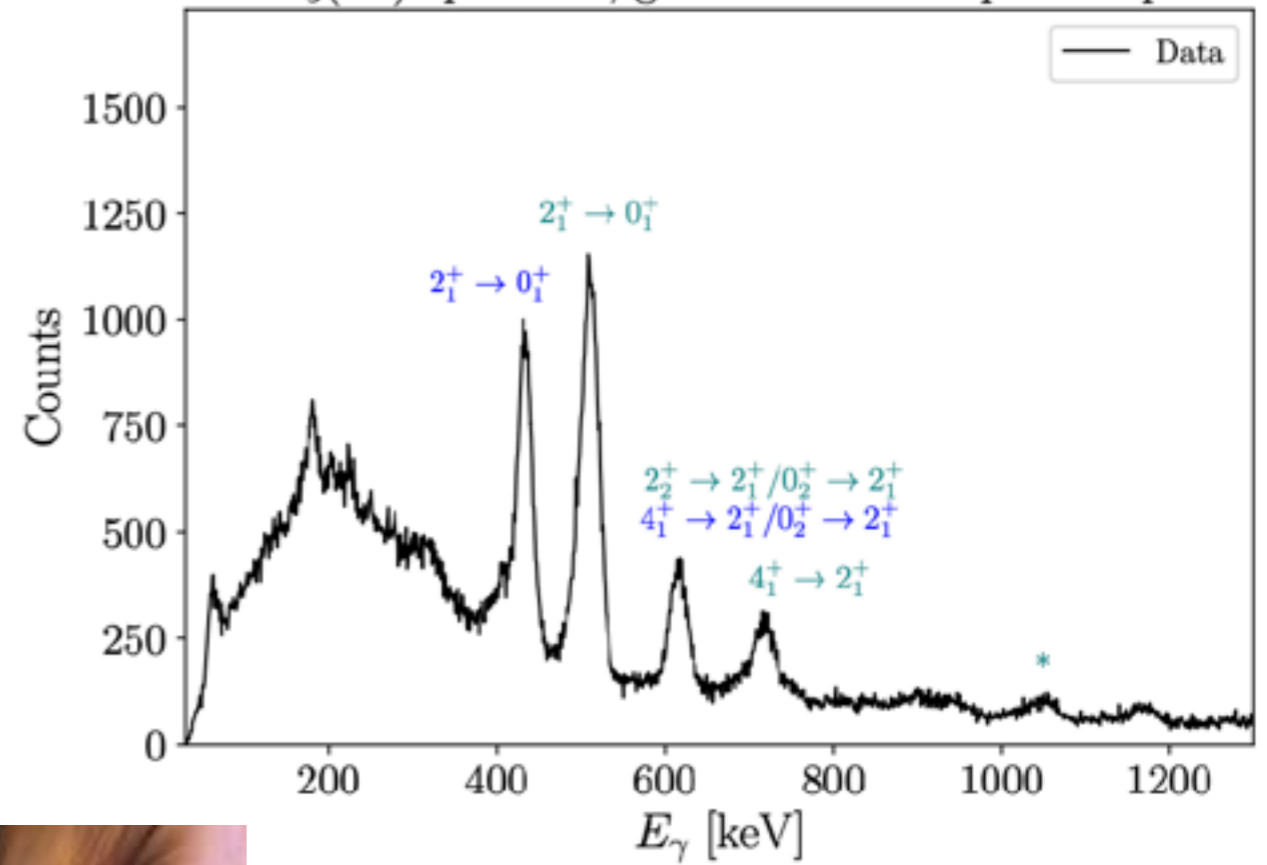

SORCERER  
x6 solar cell array





# $^{106}\text{Pd}$

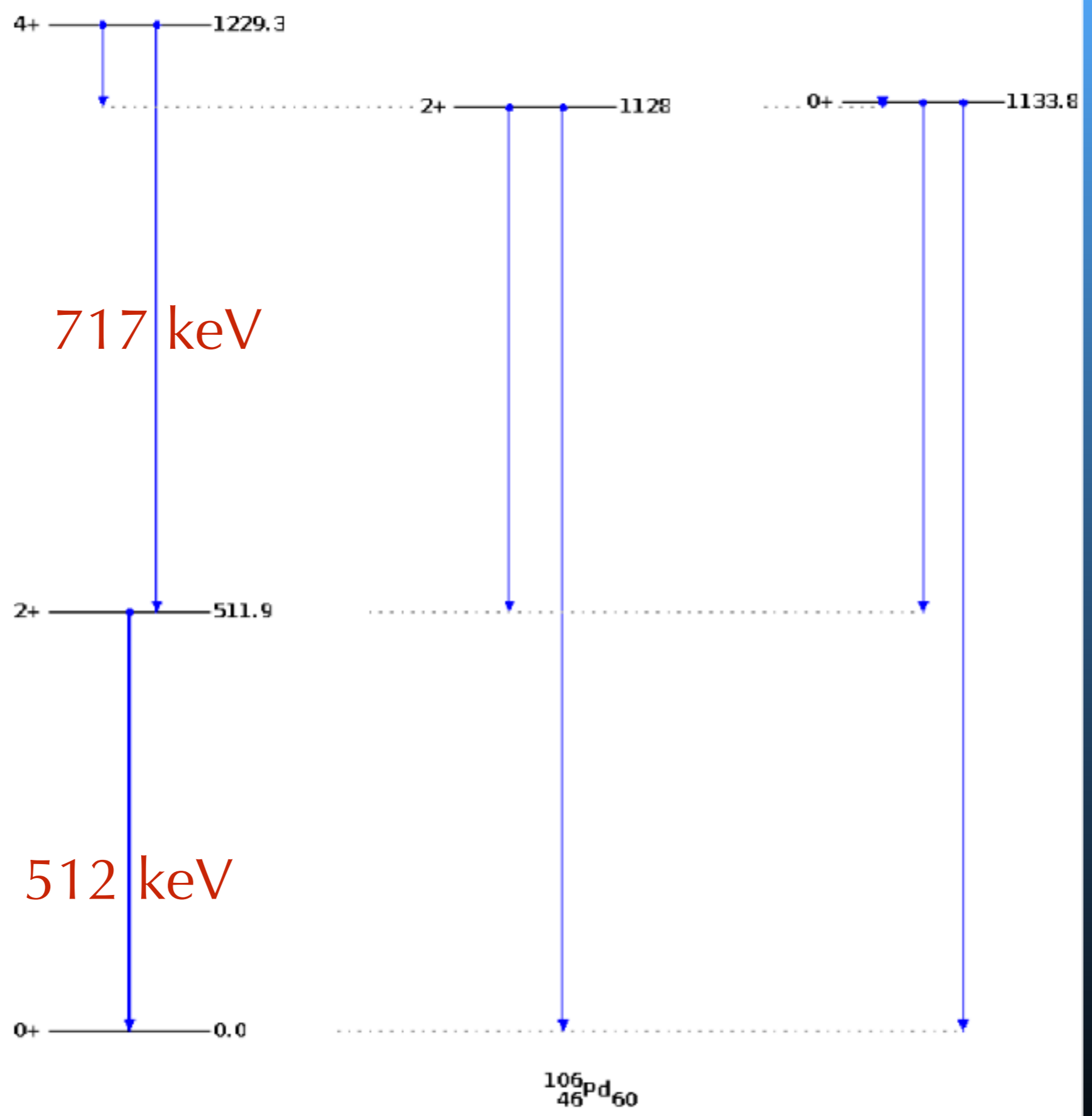

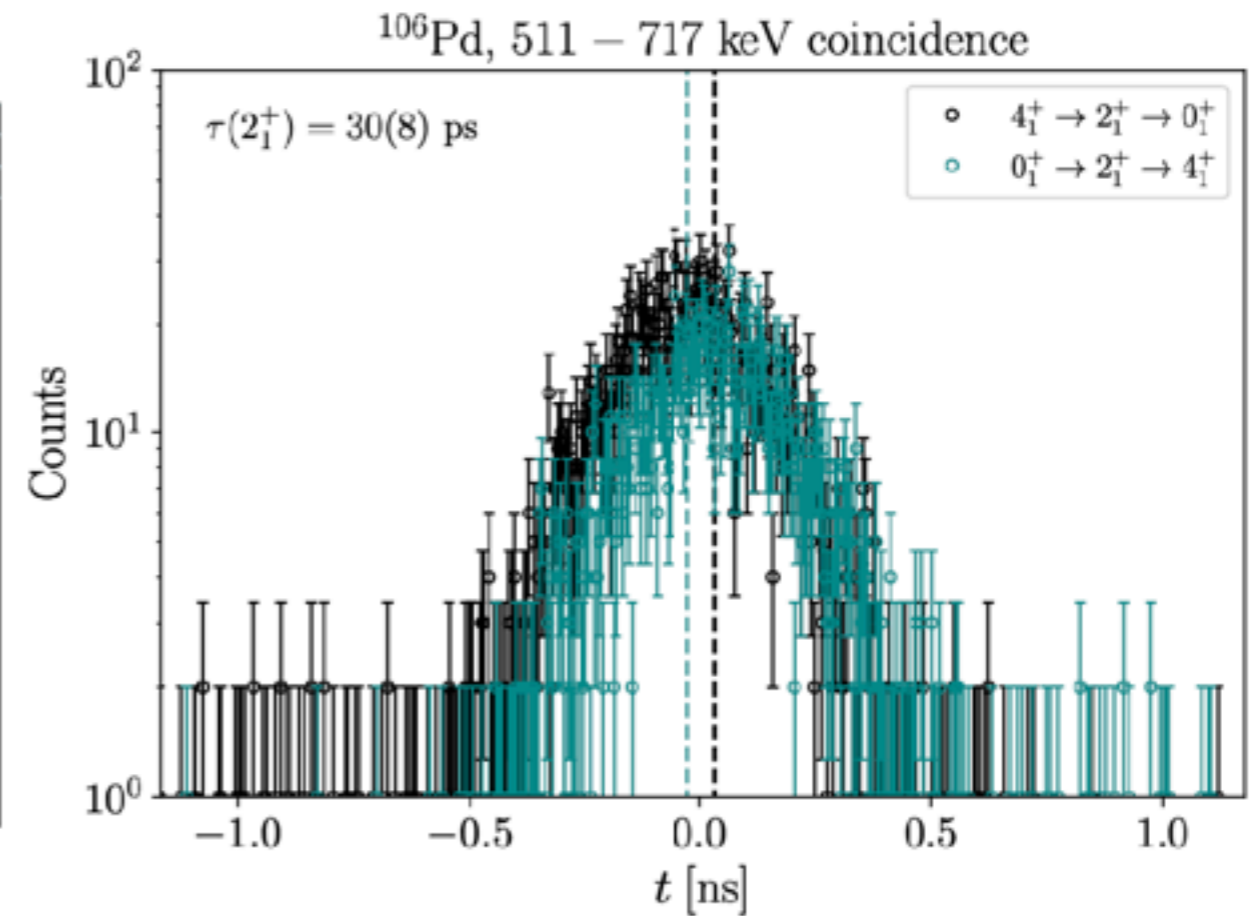
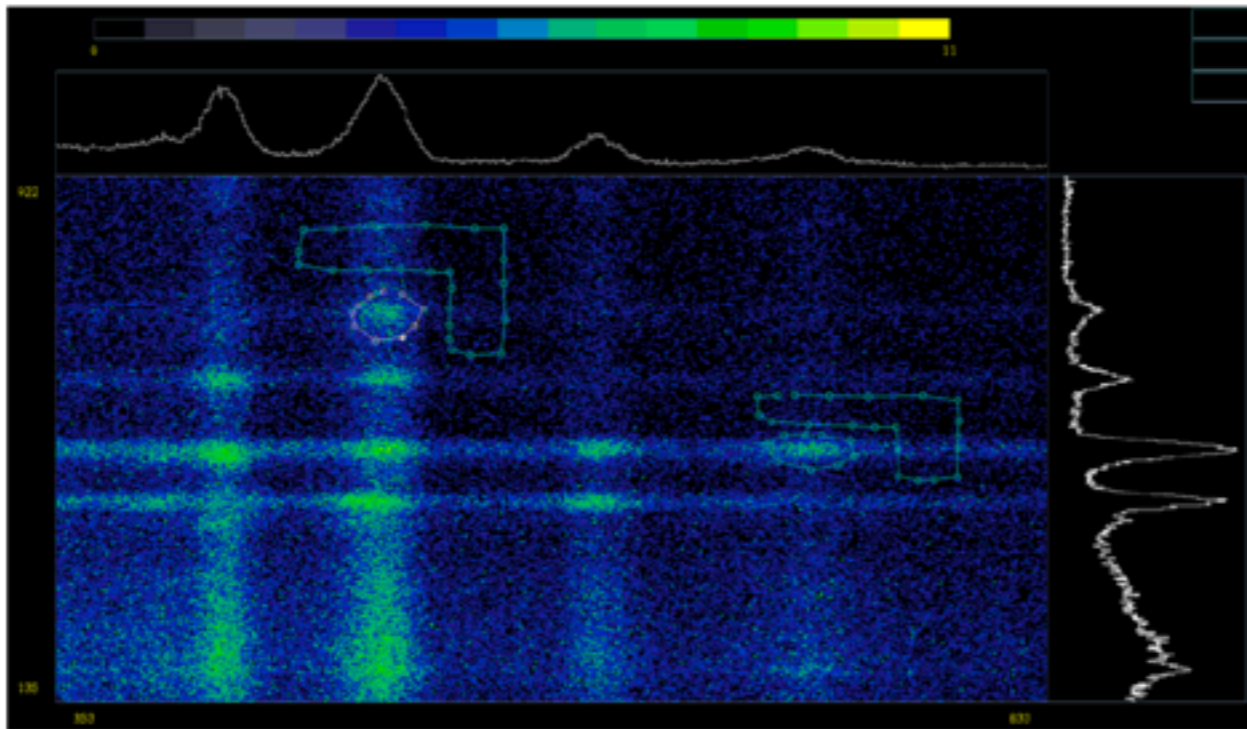
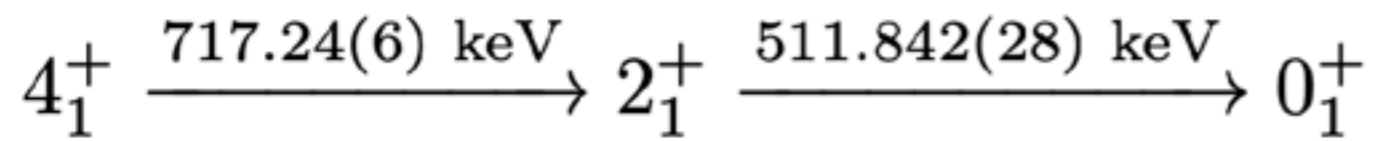



# $^{106}\text{Pd}$ ( $2_1^+$ state)

$E_\gamma$ [keV]	$\tau$ [ps]	$B(E2)$ [W.u.]	
511.842(28)	30(8)	26(7)	This Work
	$17.50^{+48}_{-45}$	44.3(12)	

The dry run on FEST provides a disagreement with the adopted value

The extracted  $B(E2)$  value suggests a collective character of the  $2_+$  state



# Lifetimes in $^{115,117}\text{Te}$ and $^{115,117}\text{Sb}$

Activation method  $\rightarrow$  lifetime measurements

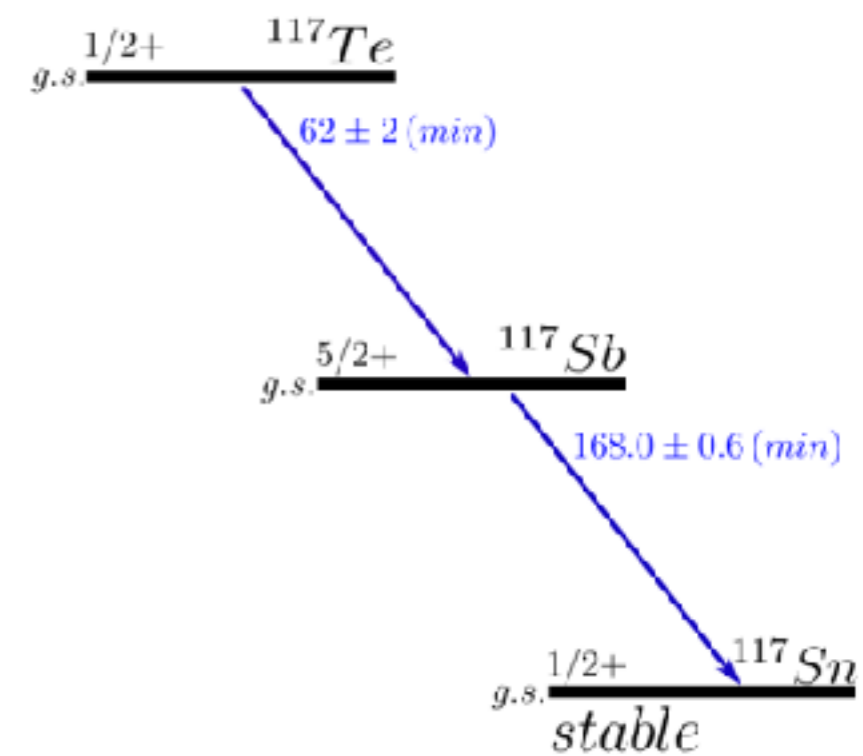
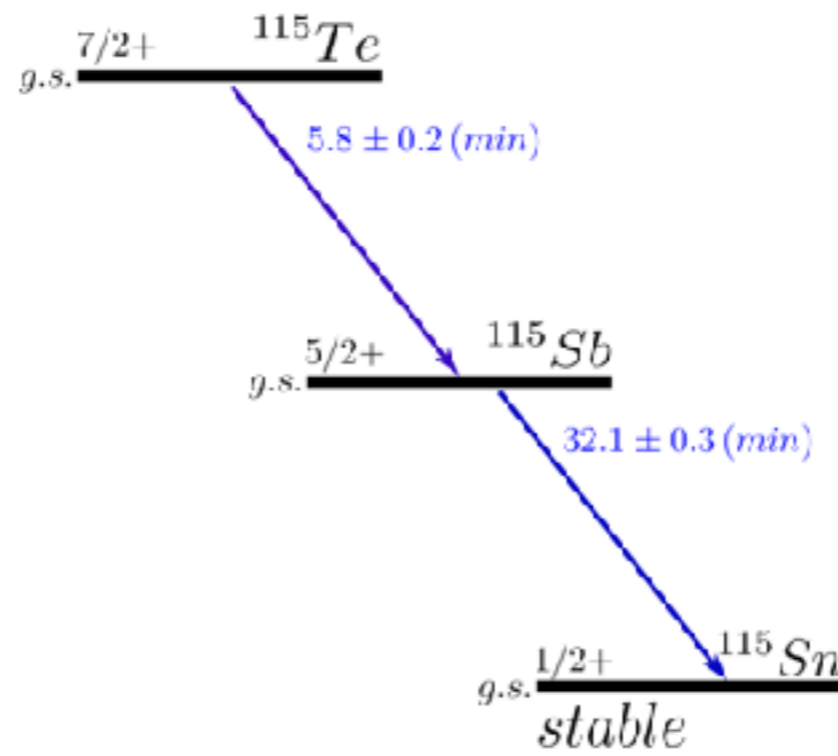
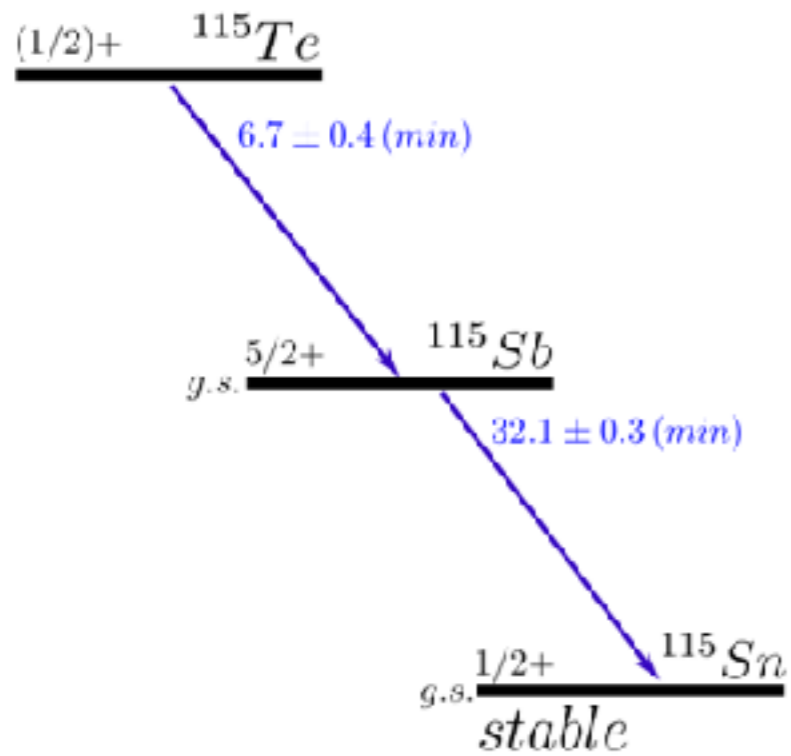

Literature data (source NNDC)

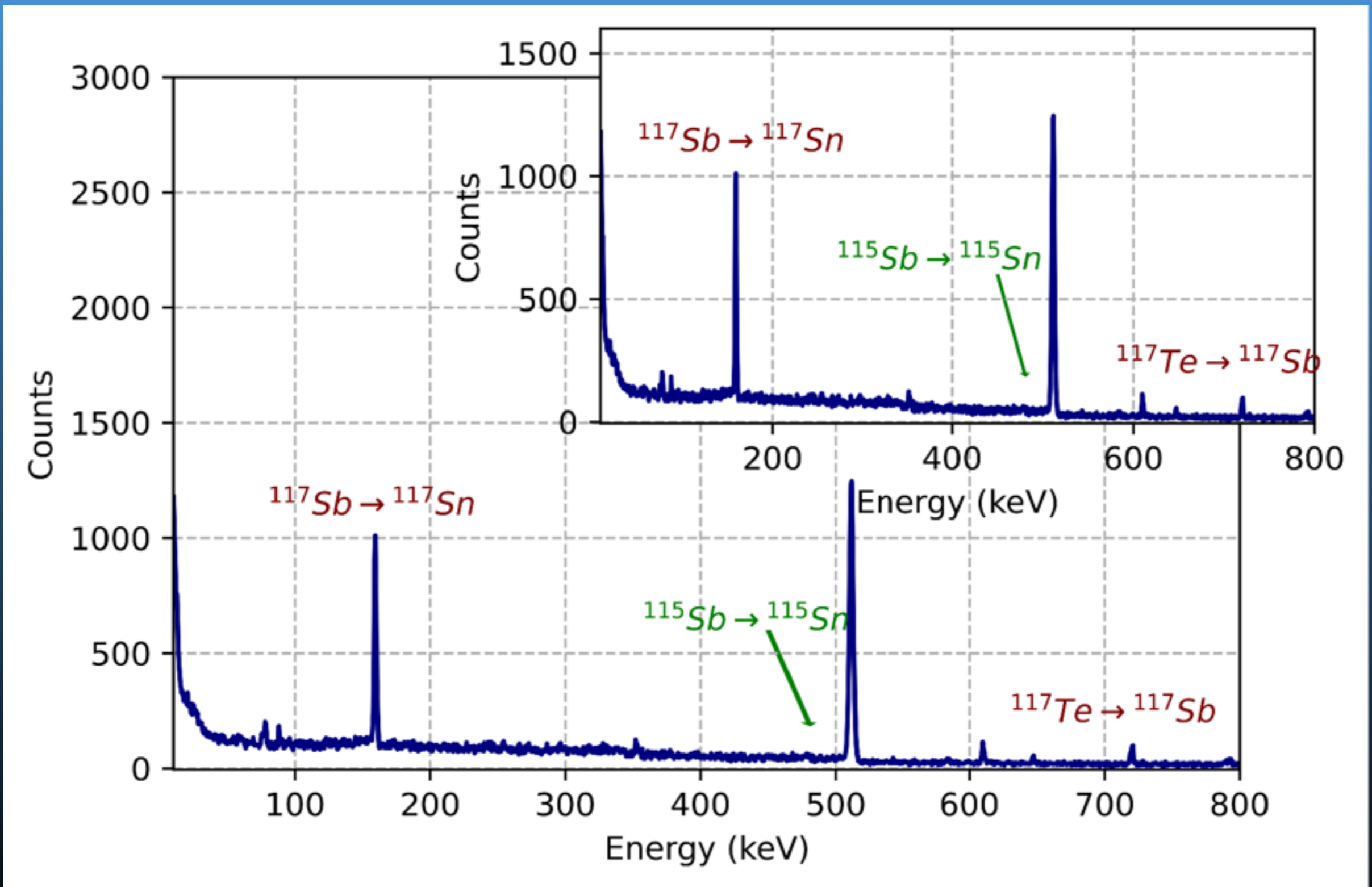



# Decay curves

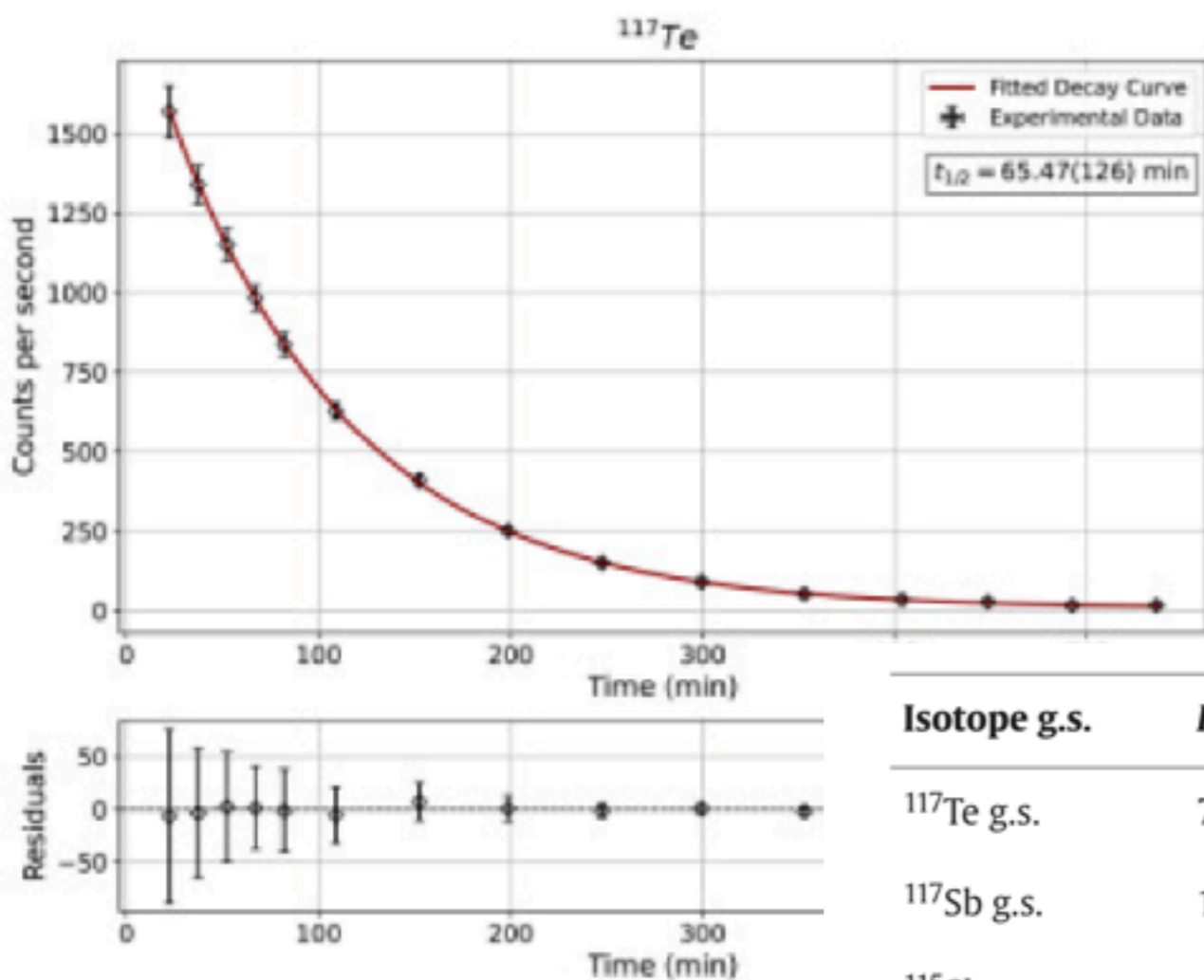
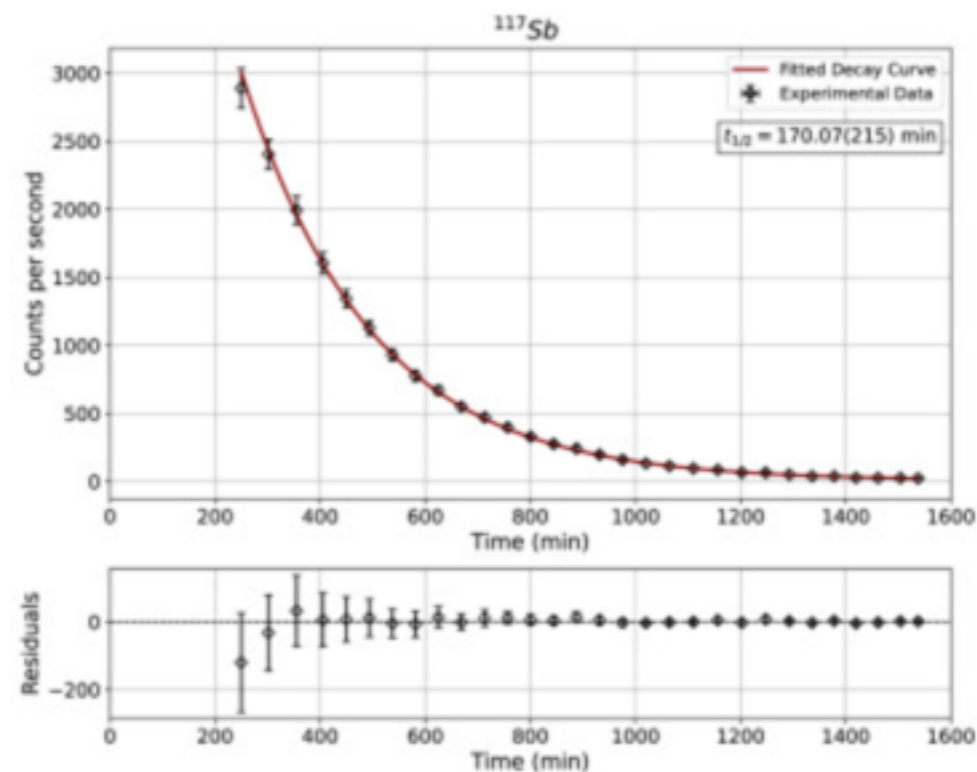
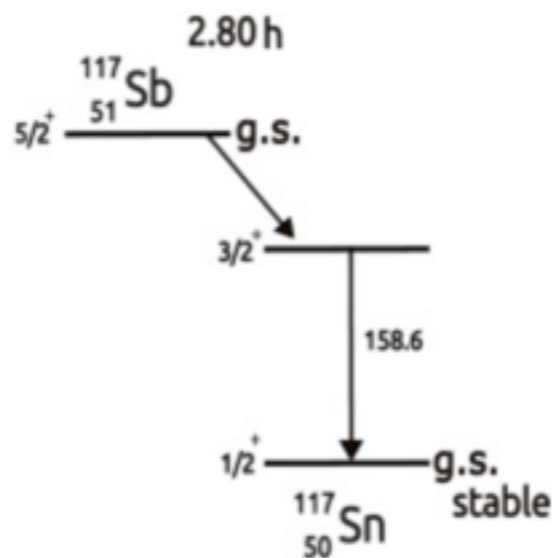
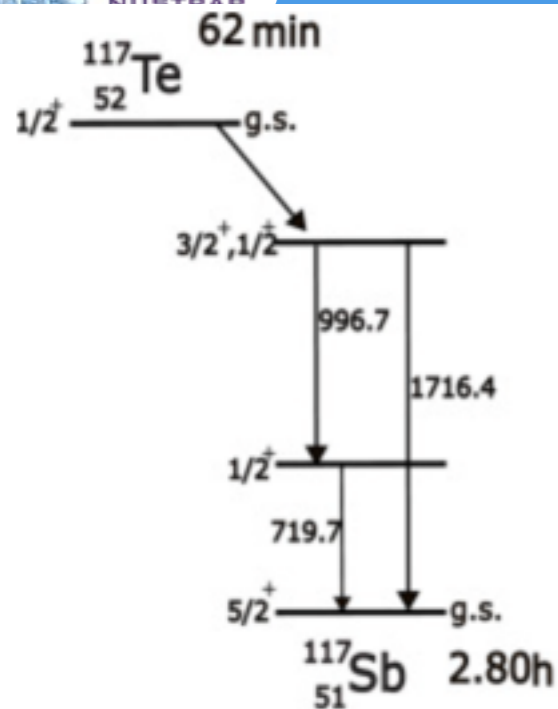

MargEf et al  
10.1016/j.nuclphysa.2026.123338

Isotope g.s.	$E_{\text{IV}} \text{ (keV)}$	Suggested Weighted Average (min)	NNDC (min)
$^{117}\text{Te}$ g.s.	719.7(7)	63.85(99)	62(3)
$^{117}\text{Sb}$ g.s.	158.6(15)	170.97(50)	168.0(6)
$^{115}\text{Sb}$ g.s.	497.3(8)	31.94(14)	32.1(3)

DDCM method



beam: 47 MeV

RoSPHERE: 25 HPGe

6 distances: 15–260  $\mu\text{m}$

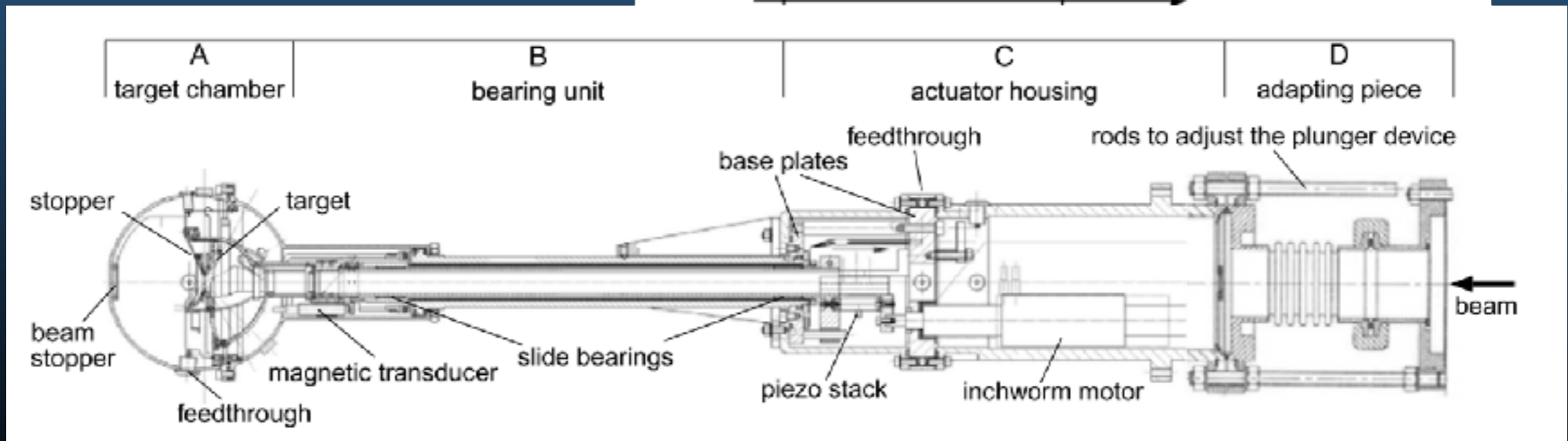
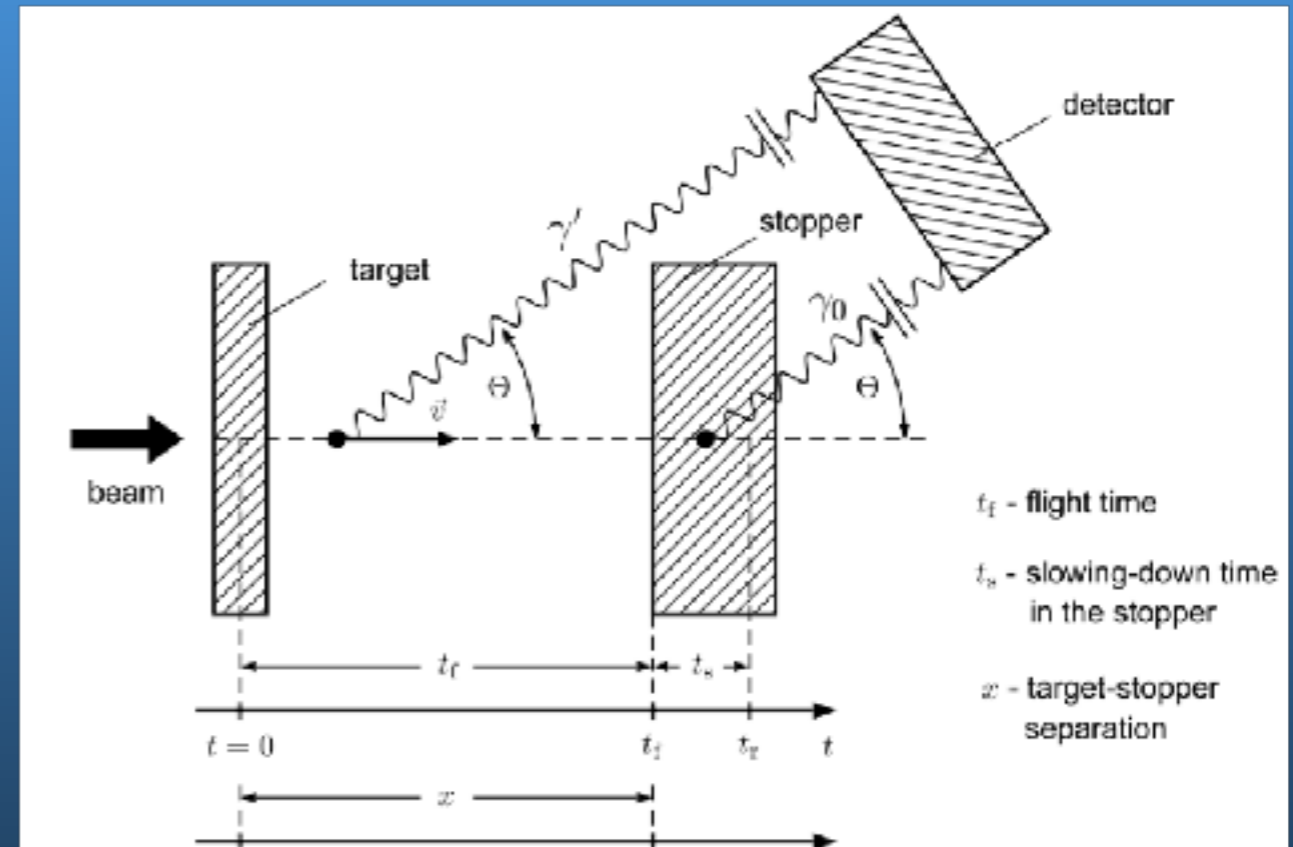

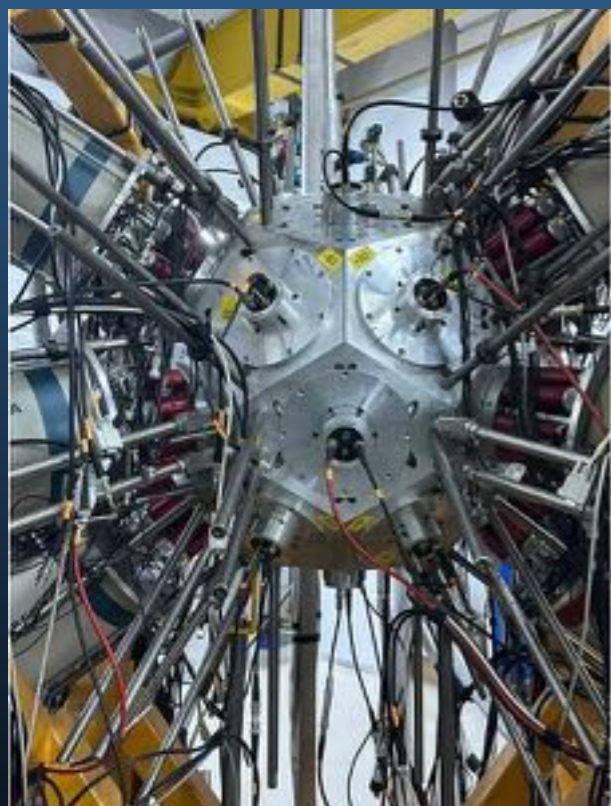
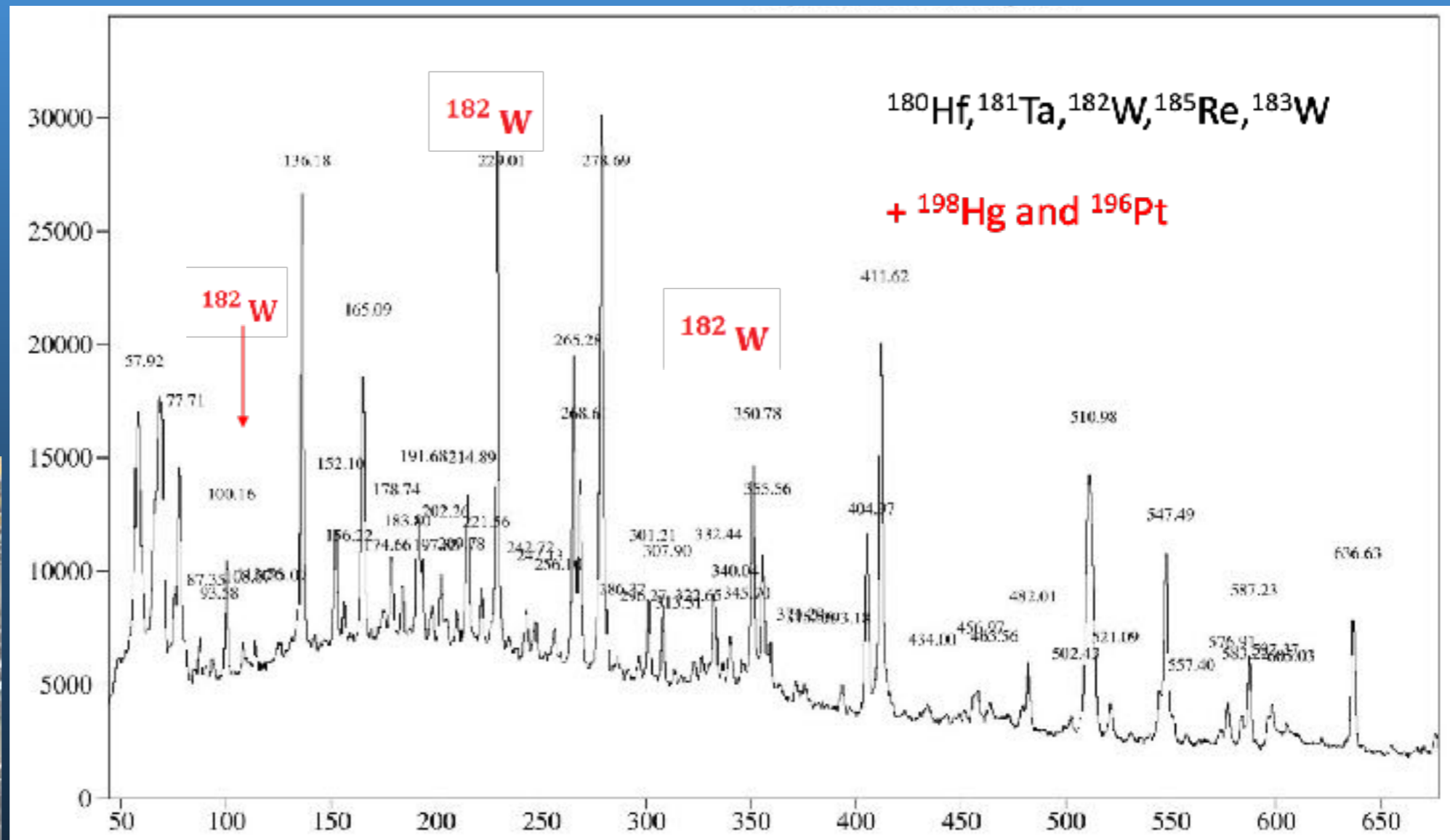

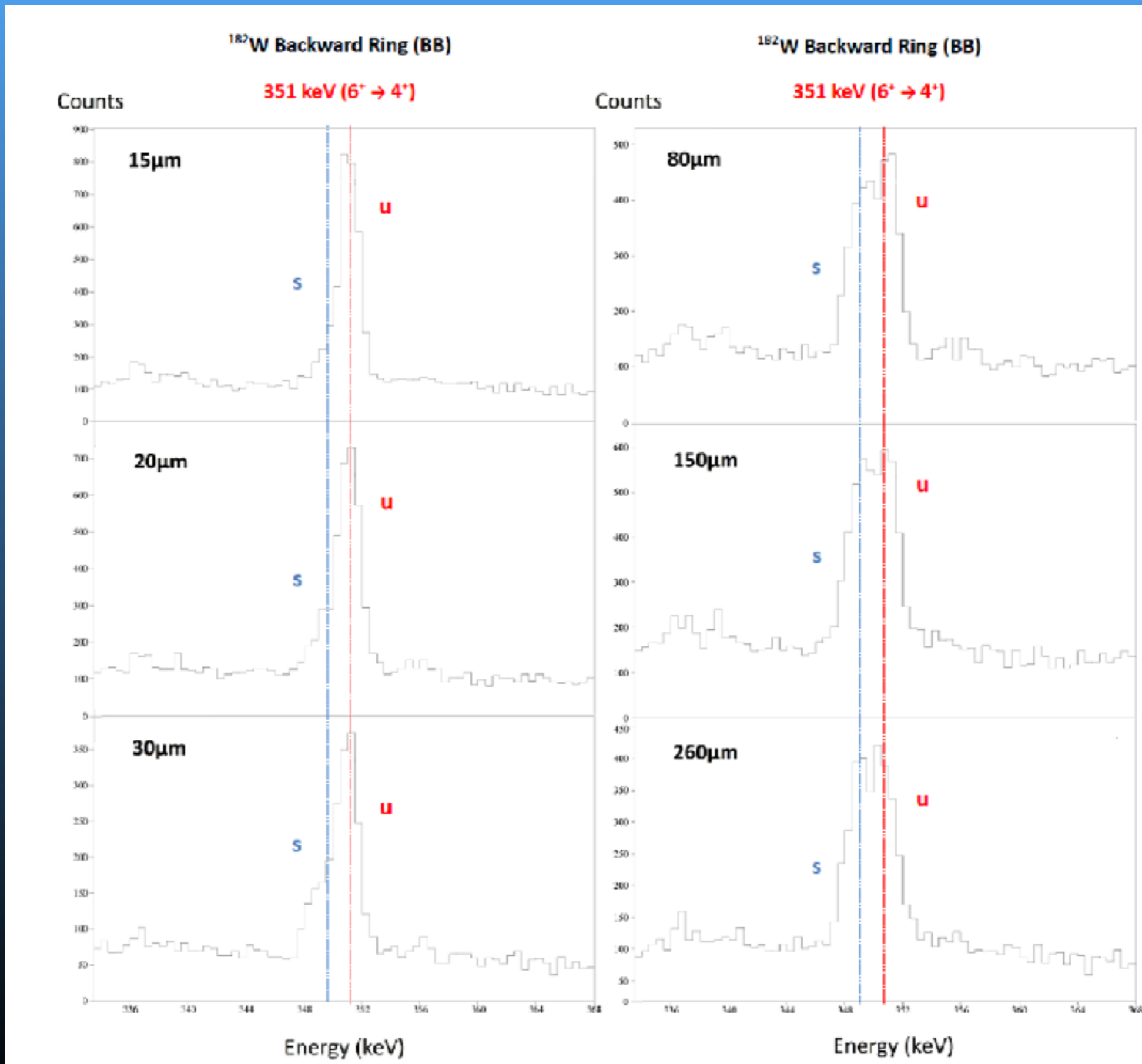

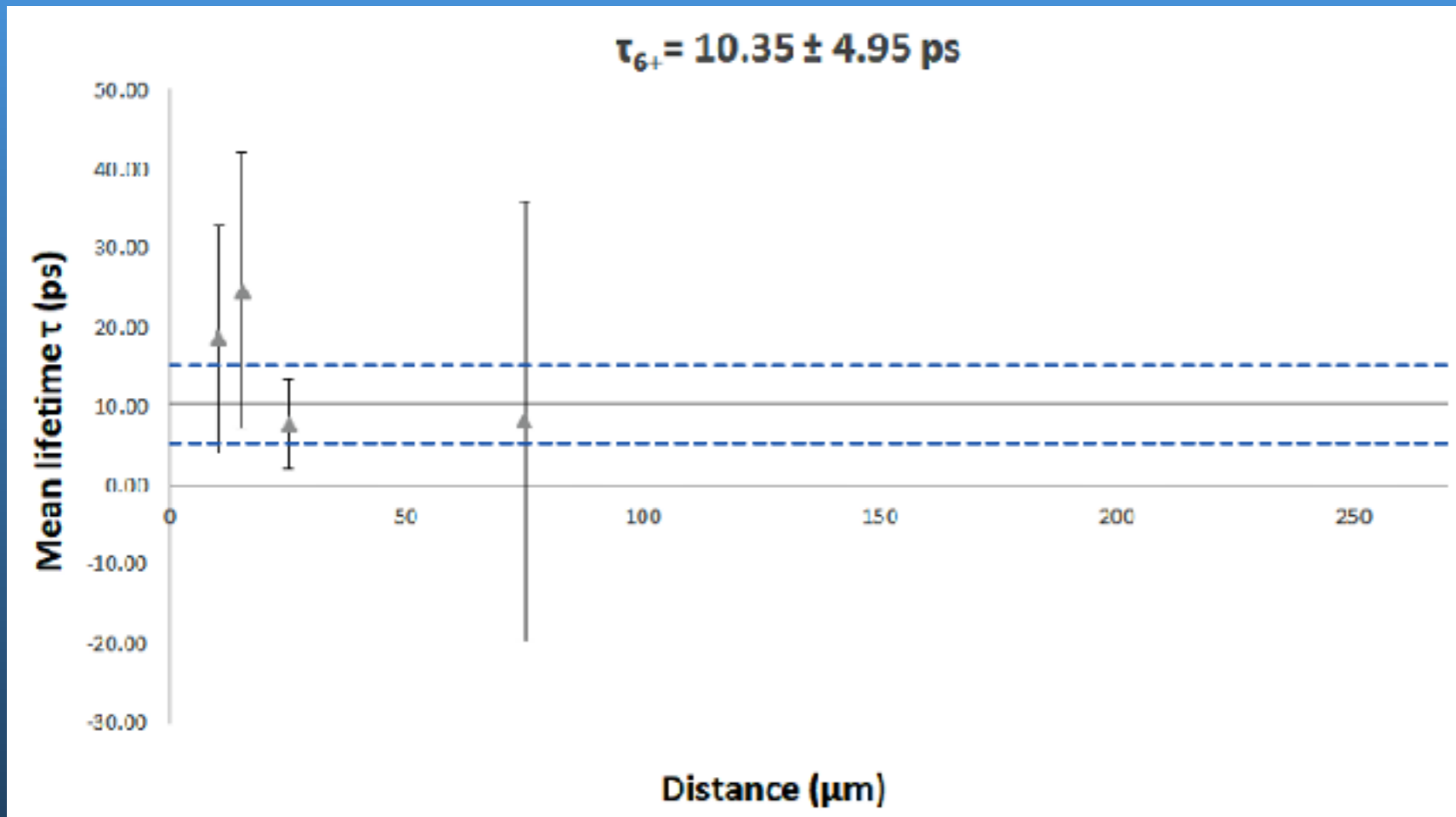

$$\tau(x) = \frac{I_{u_A}^{SB}(x)}{\frac{d}{dx} I_{s_A}^{SB}(x)} \frac{1}{u}$$

A. Zyriliou (PhD thesis)

$t_{1/2}$ (ps) for 6+	$^{182}\text{W}$
literature	8.2 (9)
this work	7.2 (34)



# More work:

- Spectroscopy studies
- branching ratios
- $\beta$ ,  $\gamma$  bands
- lifetimes  $\longrightarrow$   $B(E2)$   $\longrightarrow$   $Q_{sp}$  moments
- CoulEx studies
- Need proxy-SU(3)  $B(E2)$
- on theory side:
  - octupole moments (S. Bofos)
  - CBS (J.A. Papadopoulos)
  - CoulEx, TALYS, FRESCO...